

## RCS Clamping Element

Clamping elements are designed to be used for holding a position when using SBI Linear Rail Guides.

For other types contact Rollco.

Compatible with Linear Rail SBI only.

Dimensions in mm.



## General Data

Designation	Compatible with	Remark	Tightening Torque (Nm)	Clamping Force (N)
<b>RCS15</b>	SBI15, SBI15-B	Use Distance Plate RCP15-4 for SBI15SL	5	1200
<b>RCS20</b>	SBI20, SBI20-B	Use Distance Plate RCP20-2 for SBI20FL, SBI20SL, SBI20FLL, SBI20SLL	5	1200
<b>RCS25</b>	SBI25, SBI25-B	Use Distance Plate RCP25-4 for SBI25SL, SBI25SLL	7	1200
<b>RCS30</b>	SBI30, SBI30-B	Use Distance Plate RCP30-3 for SBI30SL, SBI30SLL	15	2000
<b>RCS35</b>	SBI35, SBI35-B	Use Distance Plate RCP35-7 for SBI35SL, SBI35SLL	15	2000

## Dimensions

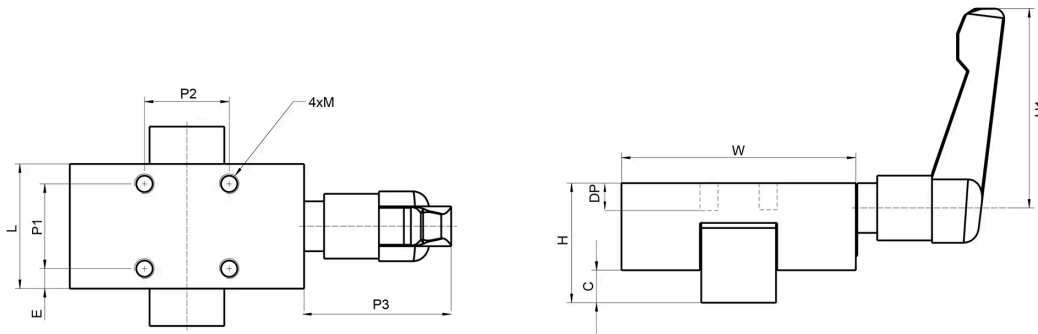

Designation	C	E	H	H1	L	MxDP	P1	P2	P3
RCS15	6.5	4	24	45	25	M4x6	17	17	41
RCS20	7	4.5	30	45	24	M5x6	15	15	41
RCS25	7	5	36	64	30	M6x8	20	20	52
RCS30	9	8.5	42	64	39	M6x14	22	22	52
RCS35	13	7.5	48	83	39	M8x14	24	24	67

Designation	W
RCS15	47
RCS20	60
RCS25	70
RCS30	90
RCS35	100