

Standard Fastening Set

Application:

Simple connection that creates an anti-rotation link for two profiles.

Assembly:

Drill $\varnothing 7$, 20mm from the profile end, in the middle of the slot, through hole.

Thread M8 in the end of the connection profile, 18mm deep.

Supply:

Standard fastener and 1xK6S ISO7380 M8x20.

Material: Zinc plated steel

System: 40 - Slot 8

Type: Fasteners



Machining:
 Drill hole (a) $\varnothing 7$ mm
 Distance (b) 20 mm
 Thread (M) M8
 Depth of thread (T) 18 mm

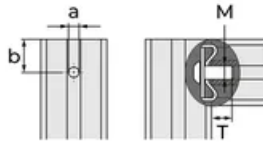

General Data

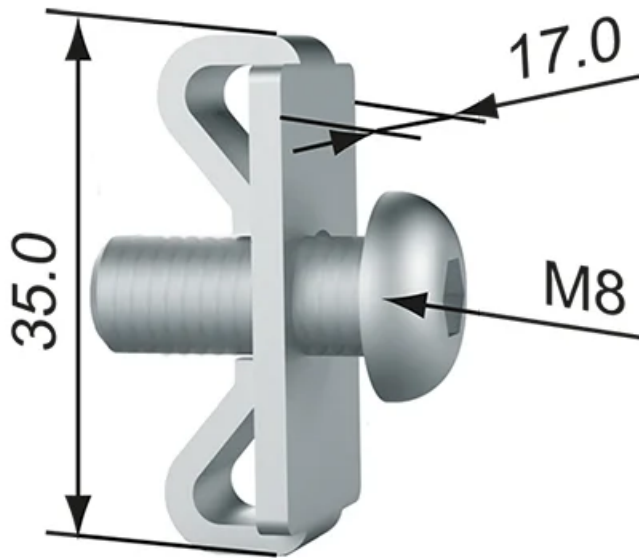

Designation	System	Torque (Nm)	Weight (g)
RF1022	40 - Slot 8	25	35