

TECHNICAL INFORMATION

TELESCOPIC RAIL HEAVY



Information in this document is subject to change. Owing to continued product development, Rollco reserves the right to make alterations without prior notice. Every care has been taken to ensure the accuracy of the information, but no liability can be accepted for any errors or omissions.

All information and content included in this document, such as text, and images, are property of Rollco. Any reproduction, even partial, is allowed only by written permission by Rollco.

Index

GENERAL INFORMATION	4
Product overview	4
TECHNICAL INFORMATION	6
Selection of telescopic rail	6
Static load check	6
Fixing screws	6
Deflection	7
Static load	8
Service life	9
Load capacity factor δ	10
Extension and extraction force	10
Double-sided stroke	10
Special strokes	11
Clearance and preload	11
INSTALLATION INSTRUCTIONS	12
General	12
ASN	12
DE/DBN	12
DS	12
OPERATING CONDITIONS	13
Speed	13
Temperature	13
Anticorrosive protection	13
Lubrication	13
ORDER CODE	14
ASN, DSS, DSD & DBN Series	14
DE Series	14

Product overview

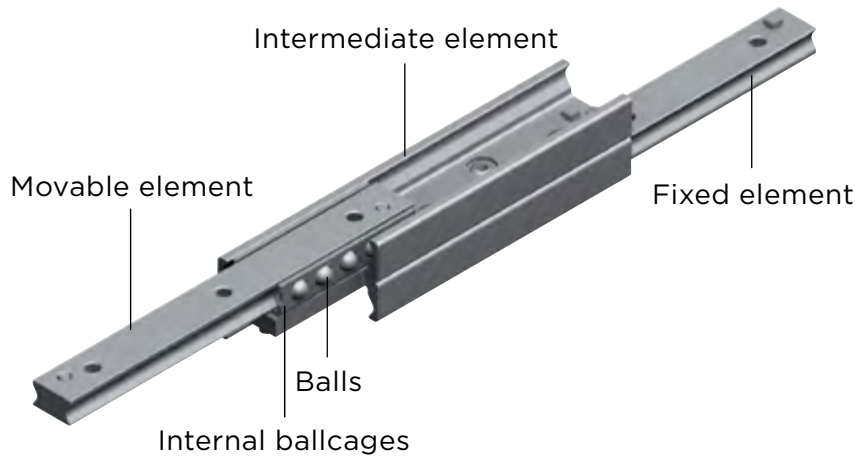

The Telescopic Rail Heavy range consists of versions with full and partial extension and various cross-sections and intermediate elements in S-shape, double-T or square. High loads in combination with cost-efficiency and free movement have long been the outstanding properties of the telescopic rail product line.

Characteristics

- High load with low deflection.
- Rigid intermediate elements.
- Standardised gauge for holes.
- Zero-play running even with maximum load.
- Space saving design.
- High reliability.

Application areas

- Railcars (e. g. maintenance and battery extensions, doors).
- Construction and machine technology (e.g., housings and doors).
- Logistics (e.g., extensions for containers or gripper movements).
- Automotive technology.
- Packaging machines.
- Beverage industry.
- Special machines.

Technical Data

- Available sizes:
ASN / DE: 22, 28, 35, 43, 63
DS: 28, 43
DBN: 22, 28, 35, 43
- Rails and sliders made of cold-drawn bearing steel.
- Induction hardened raceways.
- Balls made of hardened bearing steel.
- Max. operating speed: 0.8 m/s (depending on application).
- Electrolytic galvanised as per ISO 2081 for increased anticorrosion protection (option).
- Temperature range:
ASN / DE / DBN: -20 °C to +170 °C (-4 °F to +338 °F)
DS: -20 °C to +80 °C (-4 °F to +176 °F)

Rail types

ASN series

Partial extension consisting of a guide rail and a slider. This compact size and simple design allow very high load capacities. The high system rigidity is formed in connection with the adjacent construction.



DS series

Full extension consisting of two guide rails made of fixed and movable elements and an S-shaped intermediate element. This has a high moment of inertia and high rigidity with slim size. This results in a high loading capacity with low deflection in the extended state. The DS series is available in three different designs: Version S with one-sided extension, Version B with locking in the extracted state for one-sided extension (DSB) and Version D with double-sided extension (DSD).



DE series

Full extension consisting of two guide rails, combined as double-T profile, form the intermediate element, and two sliders, which as fixed and movable element form the connection to the adjacent construction. The square cross-section allows a compact size with high load capacities and low deflexion, especially with radial loading. A custom design is available for extensions with double-sided strokes. The simultaneous movement of the intermediate element is implemented with a driving disc.



DBN series

Full extension consisting of two guide rails, both fixed and movable, and two sliders which together form the intermediate element. The size is similar to the DE series and offers good protection from dirt of the open ballcage.



Selection of telescopic rail

Selecting the suitable telescopic rail should be done based on the load and the maximum permissible deflection in the extended state. The load capacity of a telescopic rail depends on two factors: the loading capacity of the ballcage and the rigidity of the intermediate element. For mainly short strokes the load capacity is determined by the load-bearing capacity of the ballcage; for average and long strokes it is determined by the rigidity of the intermediate element. Therefore series, which otherwise contain comparable components, are also suited for different load capacities.

Static load check

The load capacity values stated on our websites of the corresponding series give the maximum permissible loading of a pair of rails in the middle of the two rails and in the center line of the moving element with the rails in the completely extended state. Using a pair of rails, the loading acts in the centre on both rails (see fig.).

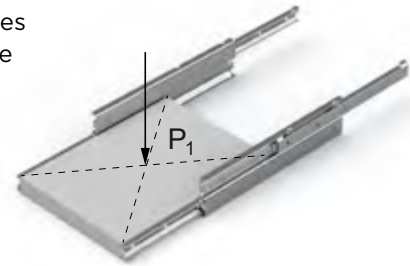

The load capacity of a rail pair is:

$$C_{Orad}$$

Fixing screws

The fixings crews are not included in the scope of supply. All rails are fixed with counter-sunk or cap head screws as per DIN 7991 or 7984. In size 63 of the ASN series, Torx® screws with low head cap screws are available on request.

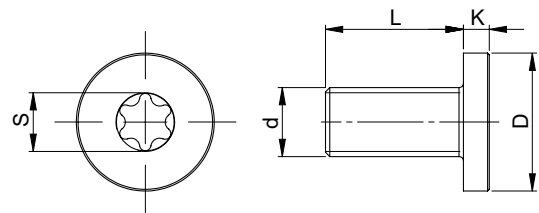

Size	Screw type	d	D	L mm	K	S
63	M8 x 20	M8 x 1,25	13	20	5	T40

Tightening torques of the standard fixing screws to be used

Property Class	Size	Tightening torque (Nm)
10,9	22	3
	28	6
	35	10
	43	25
	63	30

Prepare a sufficient bevel on the threaded fixing holes, according to the following table:

Size	Bevel (mm)
22	0.5 x 45°
28	1 x 45°
35	1 x 45°
43	1 x 45°
63	1 x 45°

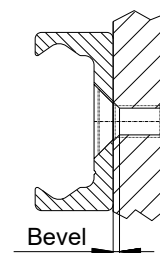

Deflection

If the load P acts vertically on the pair of rails the expected elastic deflection in the extended state can be determined as follows:

$$f = \frac{q}{t} \cdot P$$

Whereby:

f is the expected elastic deflection in mm

q is a stroke coefficient

t is a factor depending on the model of the telescopic rail

P is the actual load acting on the centre of a pair of rails, in N

DS28	t = 360
DS43	t = 1600
DE22	t = 16
DE28	t = 34
DE35	t = 108
DE43	t = 240
DE63	t = 1080
DBN22	t = 6
DBN28	t = 16
DBN35	t = 26
DBN43	t = 112

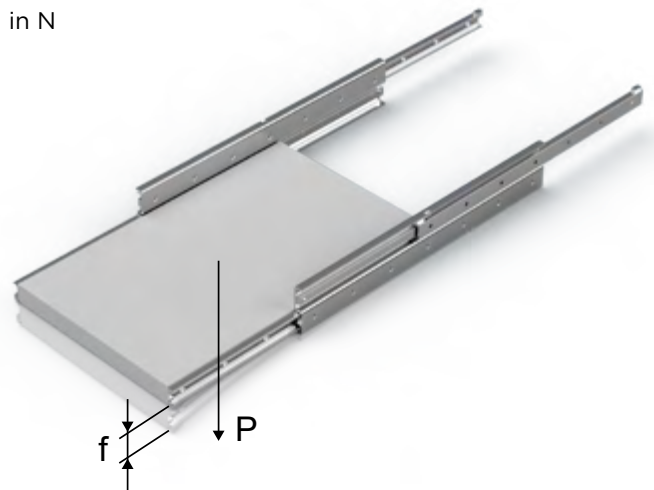

Note! This estimated value assumes an absolutely rigid adjacent construction. If this rigidity is not present, the actual deflection will deviate from the calculation.

Important! With the partial extensions of the ASN series, the deflection is almost completely determined by the rigidity, i.e. by the moment of inertia of the adjacent construction.

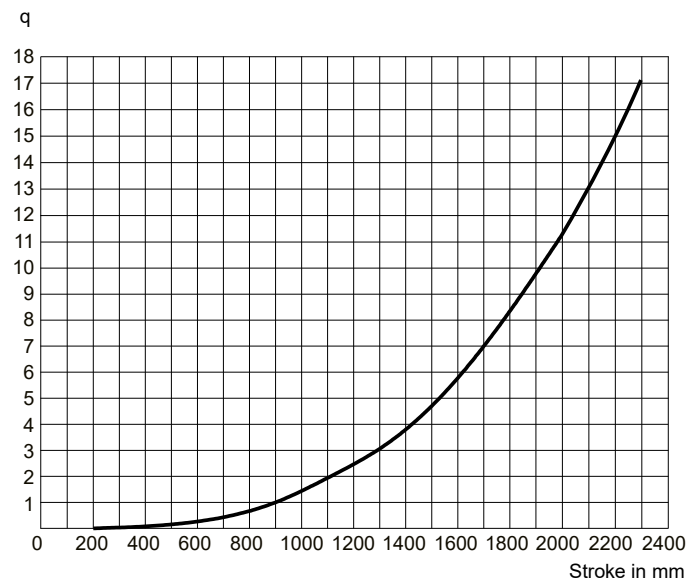

Static load

The telescopic extension of the various series accept different forces and moments. During the static tests the radial load capacity, C_{Orad} , the axial load capacity, C_{Oax} , and moments M_x , M_y and M_z indicate the maximum permissible values of the loads; higher loads negatively effect the running properties and the mechanical strength. A safety factor, S_0 , is used to check the static load, which takes into account the basic parameters of the application and is defined in more detail in the following table:

Safety factor S_0

Neither shocks nor vibrations, smooth and low-frequency reverse, high assembly accuracy, no elastic deformations	1.5
Normal installation conditions	1.5 - 2
Shocks and vibrations, high-frequency reverse, significant elastic deformation	2 - 3.5

The ratio of the actual load to maximum permissible load may be as large as the reciprocal of the accepted safety factor S_0 at the most.

$$\frac{P_{Orad}}{C_{Orad}} \leq \frac{1}{S_0} \quad \frac{P_{Oax}}{C_{Oax}} \leq \frac{1}{S_0} \quad \frac{M_1}{M_x} \leq \frac{1}{S_0} \quad \frac{M_2}{M_y} \leq \frac{1}{S_0} \quad \frac{M_3}{M_z} \leq \frac{1}{S_0}$$

The above formulas are valid for a single load case. If two or more of the described forces act simultaneously, the following check must be made:

$$\frac{P_{Orad}}{C_{Orad}} + \frac{P_{Oax}}{C_{Oax}} + \frac{M_1}{M_x} + \frac{M_2}{M_y} + \frac{M_3}{M_z} \leq \frac{1}{S_0}$$

- P_{Orad} = effective radial load
- C_{Orad} = permissible radial load
- P_{Oax} = effective axial load
- C_{Oax} = permissible axial load
- M_1 = effective moment in the x-direction
- M_x = permissible moment in the x-direction
- M_2 = effective moment in the y-direction
- M_y = permissible moment in the y-direction
- M_3 = effective moment in the z-direction
- M_z = permissible moment in the z-direction

Service life

The service life is defined as the time span between commissioning and the first fatigue or wear indications on the raceways. The service life of a telescopic rail is dependent on several factors, such as the effective load, the installation precision, occurring shocks and vibrations, the operating temperature, the ambient conditions and the lubrication. Calculation of the service life is based exclusively on the loaded rows of balls. In practice, the decommissioning of the bearing, due to its destruction or extreme wear of a component, represents the end of service life. This is taken into account by an application coefficient (f_i in the formula below), so the service life consists of:

$$L_{km} = 100 \cdot \left(\frac{\delta}{W} \cdot \frac{1}{f_i} \right)^3$$

L_{km} = calculated service life in km

δ = load capacity factor in N

W = equivalent load in N

f_i = application coefficient

Application coefficient f_i

Neither shocks nor vibrations, smooth and low-frequency direction change, clean environment	1,3 - 1,8
Light vibrations and average direction change	1,8 - 2,3
Shocks and vibrations, high-frequency direction change, very dirty environment	2,3 - 3,5

If the external load, P , is the same as the dynamic load capacity, C_{Orad} (which of course must never be exceeded), the service life at ideal operating conditions ($f_i = 1$) amounts to 100 km. Naturally, for a single load P , the following applies: $W = P$. If several external loads occur simultaneously, the equivalent load is calculated as follows:

$$W = P_{rad} + \left(\frac{P_{ax}}{C_{ax}} + \frac{M_1}{M_x} + \frac{M_2}{M_y} + \frac{M_3}{M_z} \right) \cdot C_{Orad}$$

Load capacity factor δ

Length	ASN					DS		DE.../DBN					
	22	28	35	43	63	28	43	22	28	35	43	63	
δ (N)													
130	830	1744						330	714				
210	1864	3154	3066	4576				772	1310	1228	1846		
290	2590	5384	5812	8110			1726	1074	2306	2422	3374		
370	3330	6810	7442	9588			2328	1380	2912	3104	3948		
450	4410	8238	9074	13204			2932	1850	3518	3784	5528		
530	5134	9664	11980	16902			3536	6240	2150	4126	5080	7160	
610	5872	11114	13606	20650	30006		4156	7858	2458	4744	5756	8828	12406
690	6960	12542	15234	22010	35416		4762	8394	2934	5350	6434	9322	14722
770	7684	13968	18186	25754	40854		5368	10020	3232	5958	7762	10986	17054
850		16222	19806	29524	46310		6360	11672		6974	8436	12670	19398
930		17622	21428	30858	51778		6948	12180		7566	9110	13144	21750
1010		19048	24402	34620	57258		7556	13832		8172	10452	14822	24110
1090		20474	26018	35962	62748		8162	15500		8776	11122	16514	26476
1170		21900	27636	39720	68242		8768	15292		9382	11794	16978	28846
1250			30622	43494	73742		9792	17658			13146	18664	31220
1330			32236	44822	79246		10386	18154			13814	19136	33596
1410			33850	48590	84754		10992	19818			14484	20818	35974
1490			36846	52372	90266		11612	21492			15840	22510	38356
1570				56166	95780			21976				24210	40738
1650				57466	101296			23650				24660	43122
1730				61252	106814			25330				26356	45508
1810				62562	112332			25808				26812	47896
1890				66344	117854			27486				28504	50284
1970				67658	123376			27966				28966	52672

Extension and extraction force

The required actuation forces of a telescopic rail depend on the acting load and the deflection in the extended state. The force required for opening is principally determined by the coefficient of friction of the linear bearing. With correct assembly and lubrication, this is 0.01. During the extension, the force is reduced with the elastic deflection of the loaded telescopic rail. A higher force is required to close a telescopic extension, since, based on the elastic deflection, even if it is minimal, the movable rail must move against an inclined plane.

Double-sided stroke

For all designs allowing double-sided stroke, it must be observed that the position of the intermediate element is defined only in the extended state. In the extracted state, the intermediate element can protrude by half of its length on each side. Exception is the ASN series, which comes out as a partial extension without an intermediate element and the custom design of series DE with driving disc. The double-sided stroke in series ASN, DE and DBN is achieved by removing the set screw. For series DS version D, the double-sided stroke is implemented by design adaptation.

Special strokes

Special strokes are defined as deviations from standard stroke H. The special strokes are available in steps according to the column Stroke modification in the table below. These values are dependent on the spacing of the ballcage.

ASN-22-130 has a standard stroke of 76 mm (value from Rollco.se). Example of special stroke for this size: $76 + 7.5 = 83.5$ mm. Possible to continue in steps of 7.5 mm. Order code: ASN-22-130-83.5

Type	Size	Stroke modification (mm)
ASN	22	7.5
	28	9.5
	35	12
	43	15
	63	20
DSS DE DBN	22	15
	28	19
	35	24
	43	30
	63	40

No stroke modification is possible for the DSD series.

Please be aware that there are a limit and each stroke modification influences the load capacities stated in this document and on our website. It is possible that after a stroke modification important fastening holes might no longer be accessible. The maximal modified stroke of ASN-type is 65% of the rail-length and 130% for DSS, DE and DBN. For more information please contact Rollco.

Clearance and preload

Telescopic rail guides are mounted as standard with no play. For more information, please contact Rollco.

Preload classes		
Increased clearance	No clearance	Increased preload
G1	Standard	K1

Remarks

- Horizontal installation is recommended.
- Vertical installation on request, please contact Rollco.
- External end stops are recommended.
- Double-sided stroke.
- Custom strokes on request.
- All load capacity refer to a pair of rails.
- All load capacity data are based on continuous operation.
- Calculation of the service life is based exclusively on the loaded rows of balls.
- ASN 63 can be fixed with Torx® screws as an alternative.
- Fixing screws of property class 10.9 must be used for all telescopic rails.
- Internal stops are used to stop the unloaded slider and the ball cage.
Please use external stops as end stops for a loaded system.

Installation instructions

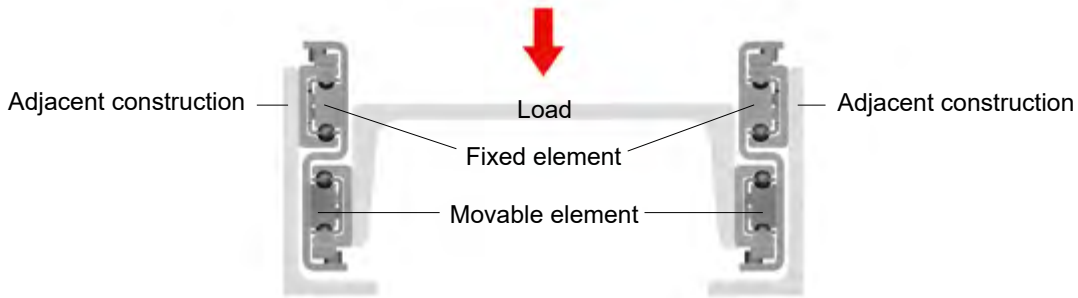

General

- Internal stops are used to stop the unloaded slider and the ball cage. Please use external stops as end stops for a loaded system.
- To achieve optimum running properties, high service life and rigidity, it is necessary to fix the telescopic rails with all accessible holes on a rigid and level surface. When using two telescopic rails, please observe the parallelism of the installation surfaces. The fixed and movable rails fit to the rigid assembly construction.
- Telescopic Rail guides are suitable for continuous use in automatic systems. For this, the stroke should remain constant in all moving cycles and the operating speed must be checked. The movement of the telescopic rails is enabled by internal ballcages, which could experience an offset from the original position with differing strokes. This phase offset can have a negative effect on the running properties or limit the stroke. If differing strokes occur in an application, the drive force must be sufficiently dimensioned in order to appropriately synchronise the ballcage offset. Otherwise, an additional maximum stroke must be planned regularly to ensure the correct position of the ballcage.

ASN

- Series ASN accepts radial and axial loads and moments in all principle directions.
- Horizontal and vertical application is possible. If vertical installation, please contact Rollco.
- The installation of two partial extensions on a profile provides a load capable full extension. For individual solutions, please contact Rollco.

DE/DBN

- Series DE and DBN accept radial and axial loads.
- Horizontal and vertical application is possible. Prior to vertical installation, we recommend a check by application technology.
- The functionality of custom design DE...D is only guaranteed if the stroke available is completely used.

DS

- Series DS accept radial loads. This should act in the vertical cross-sectional axis on the movable rails.
- Horizontal and vertical application is possible. Prior to vertical installation, we recommend a check by application technology.
- When installing make sure that the load is placed on the movable element (the lower rail). The opposite assembly negatively affects the function.
- Installation must be done on a rigid adjacent construction using all accessible fixing holes.
- Pay attention to the parallel alignment during assembly with paired application.

Operating conditions

Speed

The maximum operating speed is determined by the mass of the intermediate element, which moves with the movable rail. This reduces the maximum permissible operating speed with increasing length.

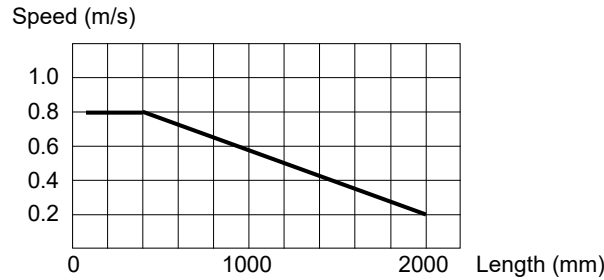

Temperature

- Series ASN, DE and DBN can be used up to an ambient temperature of +170 °C (+338 °F). A lithium lubricant for high operating temperatures is recommended for temperatures above +130 °C (+266 °F). Minimum temperature with standard grease is -20°C (-4°F)
- Series DS have a useable range of -20°C to+80°C (-4°F to +176°F) due to rubber stop.

Anticorrosive protection

- All of the Telescopic Rail product series have a standard anticorrosive protection by electrolytic galvanisation according to ISO 2081. If increased anticorrosive protection is required, the rails are available chemically nickel plated and with corrosion resistant steel balls.
- Numerous application-specific surface treatments are available upon request, e.g., as a nickel-plated design with FDA approval for use in the food industry. For more information please contact Rollco.

Lubrication

- Recommended lubrication intervals are heavily dependent upon the ambient conditions, speed and temperature. Under normal conditions, lubrication is recommended after 100 km operational performance or after an operating period of six months. In critical application cases the interval should be shorter. Please clean the raceways carefully before lubrication. Raceways and spaces of the ball cage are lubricated with a lithium lubricant of average consistency (roller bearing lubricant).
- Different lubricants for special applications are available upon request. Example: Lubricant with FDA approval for use in the food industry. For more information please contact Rollco.

ASN, DSS, DSD & DBN Series

ASN 63 - 770 - 433

Series

(ASN, DSS, DSD, DBN)

Height of slide*

(22, 28, 35, 43, 63)

Length of fixed member

Stroke example, if deviating from standard stroke

*DSS and DSD are only available in size 28 and 43.

DE Series

DE F 35 - 690 - 806

Series

(DE)

Type of hole:

F: threaded

V: countersunk

M: both variants (mixed)

(size 63 only F)

Height of intermediate member

(22, 28, 35, 43, 63)

Length of fixed member

Stroke example, if deviating from standard stroke

**ALWAYS THE RIGHT
SOLUTION AT THE RIGHT TIME.**

ROLLCO

LINEAR SOLUTIONS **YOUR WAY**

With reliability, competence and commitment Rollco rapidly delivers the right solutions and components to create safe and cost-effective automation and linear movement.

Rollco AB

Box 22234
Ekvändan 3
250 24 Helsingborg
Sweden
Tel. +46 42 15 00 40
www.rollco.se

Rollco A/S

Skomagervej 13 E
7100 Vejle
Denmark
Tel. +45 75 52 26 66
www.rollco.dk

Rollco Oy

Sarankulmankatu 12
33900 Tampere
Finland
Tel. +358 207 57 97 90
www.rollco.fi

Rollco Norge AS

Industrigata 6
3414 Lierstrada
Norway
Tel. +47 32 84 00 34
www.rollco.no